

BASIC LOADER TOWER REPLACEMENT PARTS

Ref.	Part No.	Description	Qty.
1	XAT-112AAS	TOWER	1
2	XAT-25AS	LATCH	2
3	HHS1011040	5/8" x 2-1/2" BOLT	2
4	HTN1011	5/8" LOCKNUT	2
5	XAF-54C	LINKAGE PIN W/ZERK	4
6	RLP0700036	7/16" ROLL PIN	4
7	ZER1805	GREASE FITTING	4

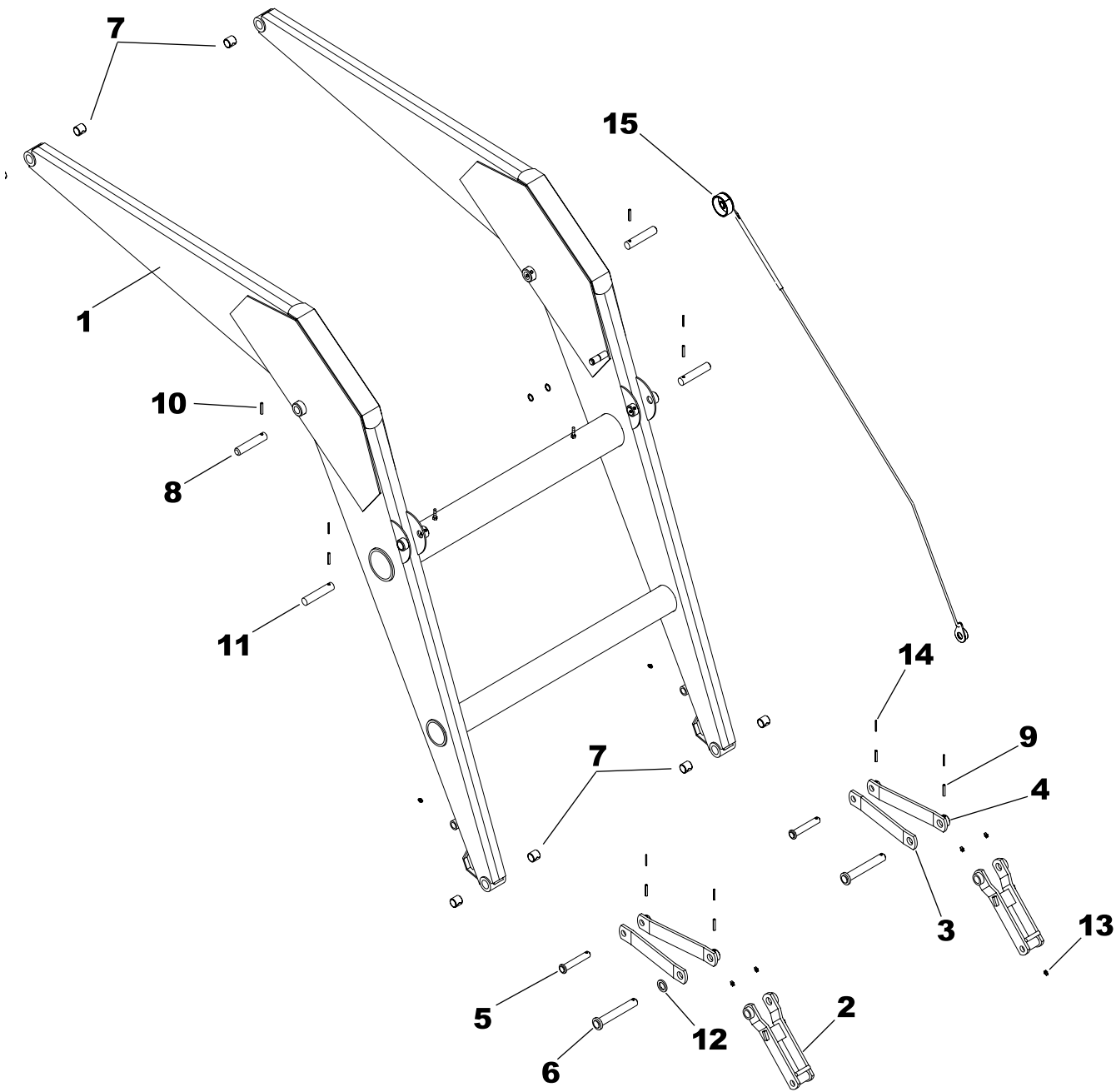

BASIC LOADER ARM REPLACEMENT PARTS

Ref.	Part No.	Description	Qty.	Ref.	Part No.	Description	Qty.
1	XAF-4AAS	FRAME	1	9	RLP0600032	3/8" x 2" ROLL PIN	6
2	NAF-15BAS	LINKAGE CONNECTOR	2	10	RLP0700036	7/16" ROLL PIN	2
3	NAF-10A	LINKAGE BAR	2	11	NAF-51A	PIN	2
4	NAF-10BAS	LINKAGE BAR W/BUSHING	2	12	NAF-117	SPACER WASHER	2
5	LMF-28AS	PIN ROUND HEAD	2	13	ZER1805	GREASE FITTING	10
6	LMF-125AS	PIN ROUND HEAD	2	14	RLP0350032	7/32" x 2" ROLL PIN	6
7	LW-32	INSERT	8	15	LAC-15-17	BUCKET INDICATOR KIT*	1
8	XAF-54C	PIN	2				

NOTE: *Bucket Indicator Kit & Height Indicator Kit, see page 7.3 for complete parts breakdown.

ROTATIONAL BUCKET INDICATOR

Ref.	Part No.	Description	Qty.
	LAC-15-17	BUCKET INDICATOR KIT*	1
1	GRD-101AS	BUCKET INDICATOR	1
2	GRD-105	GAUGE ROD HOLDER	1
3	GRD-145	GAUGE ROD	1
4	GRD-2AS	POINTER	1
5	SR-C08	SNAP RING	2
6	AHS0616006	3/8" X 3/8" ALLEN HEAD SET SCREW	2
7	DE-GRD	DECAL	1
8	HHS0616020	3/8" X 1-1/4" BOLT	1
9	HTN0616	3/8" LOCK NUT	1
10	CTK0200016	1/8" X 1" COTTER KEY	1
11	NAF-10	PIVOT STRAP	1
12	NAF-117	PIN HEAD	1

NOTE: *Order LAC-15-17 when ordering a complete Rotational Bucket Indicator Kit.

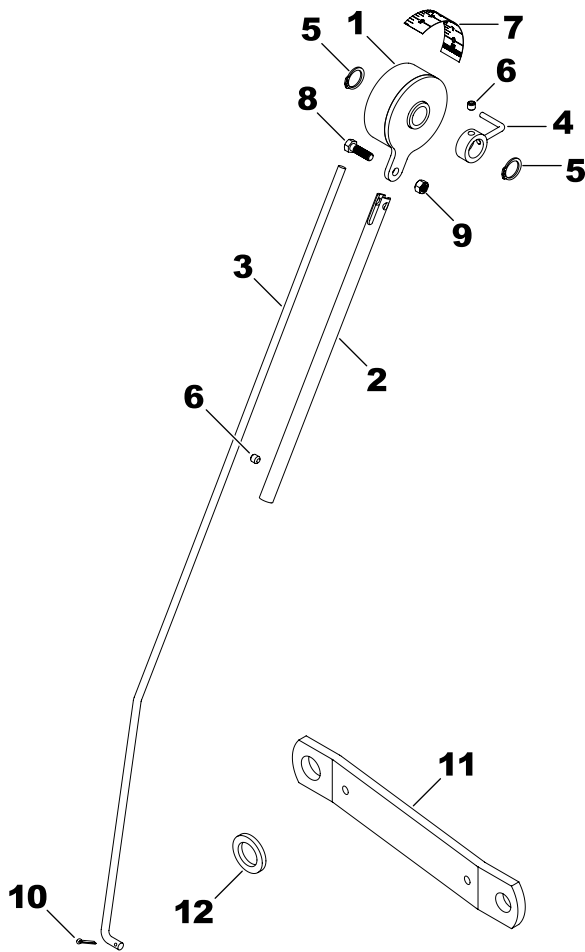

OPT. ROTATIONAL HEIGHT INDICATOR

Ref.	Part No.	Description	Qty.
	LAC-25-01	HEIGHT INDICATOR KIT*	1
1	GRD-11SUB	HEIGHT INDICATOR	1
2	GRD-2AS	HEIGHT INDICATOR POINTER	1
3	DE-GRD	DECAL	1
4	BUS-105	BUSHING	1
5	BUS-106	BUSHING	1
6	BUS-107	INSERT BUSHING	1
7	LM-4	BUSHING	1
8	XAF-154	PIN	1
9	ZER1805	GREASE ZERK	1
10	SHS0616008	3/8" X 1/2" SQUARE HEAD SET SCREW	1
11	AHS0616006	3/8" X 3/8" ALLEN HEAD SET SCREW	1
12	RLP0700036	7/16" ROLL PIN	1
13	HHS0616048	3/8" X 3" BOLT	1
14	CBF0616024	3/8" X 1-1/2" CARRIAGE BOLT	1
15	HTN0616	3/8" LOCK NUT	1

NOTE: *Order LAC-25-01 when ordering a complete Rotational Height Indicator Kit.

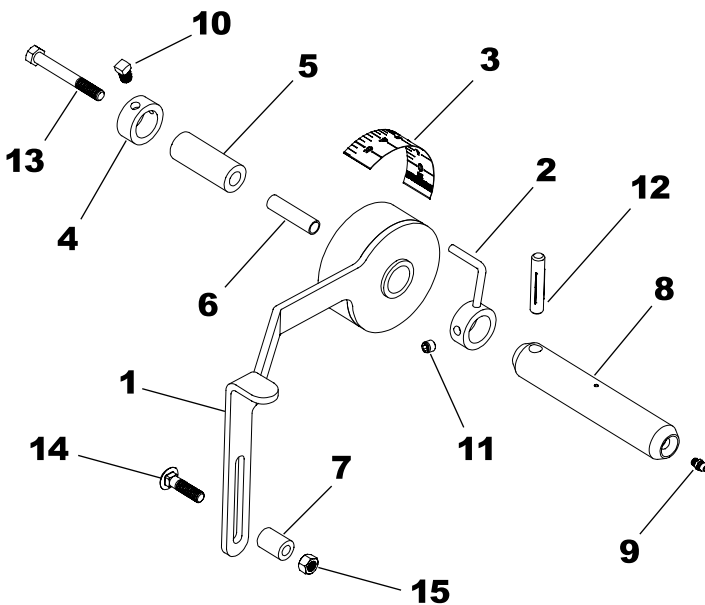

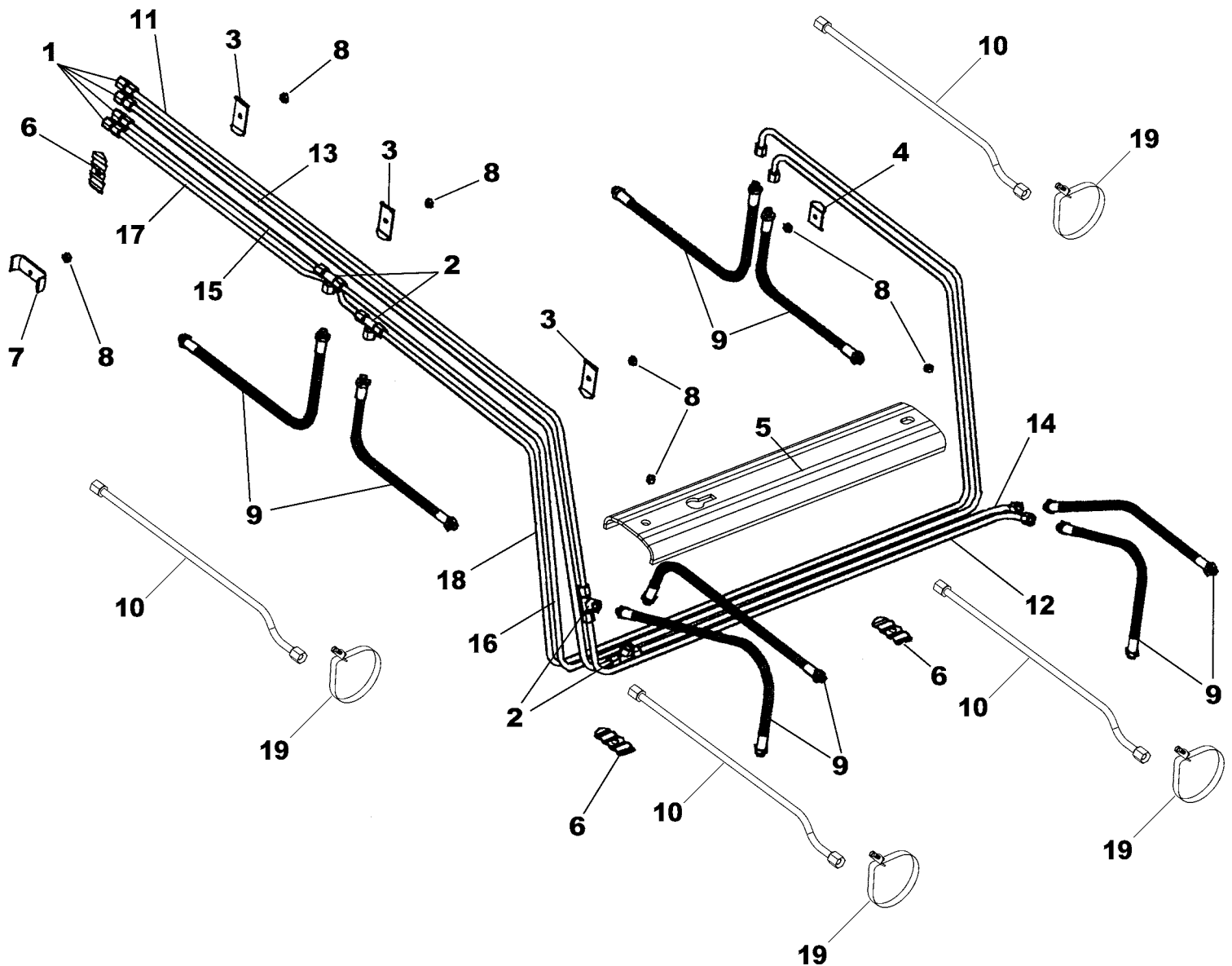

HYDRAULIC LINES

Ref.	Part No.	Description	Qty.	Ref.	Part No.	Description	Qty.
1	PF-FFC8	FLAIRLESS TO 1/2" NPT	4	11	OLT-280B	OIL LINE	1
2	PF-FSBT8	SWIVEL TEE	4	12	OLT-281B	OIL LINE	1
3	OH-3	OIL LINE HOLDER	3	13	OLT-282B	OIL LINE	1
4	OH-6A	OIL LINE HOLDER	1	14	OLT-283B	OIL LINE	1
5	OH-12	OIL LINE COVER	1	15	OLT-284B	OIL LINE	1
6	OH-14A	OIL LINE HOLDER	3	16	OLT-285B	OIL LINE	1
7	OH-19	HOSE HOLDER	1	17	OLT-286B	OIL LINE	1
8	HFN0616	3/8" HEX NUT	7	18	OLT-287B	OIL LINE	1
9	H06020FF	3/8" x 20" HOSE	8	19	BAND-15	METAL BAND	4
10	OLT-1	OIL LINE	4				

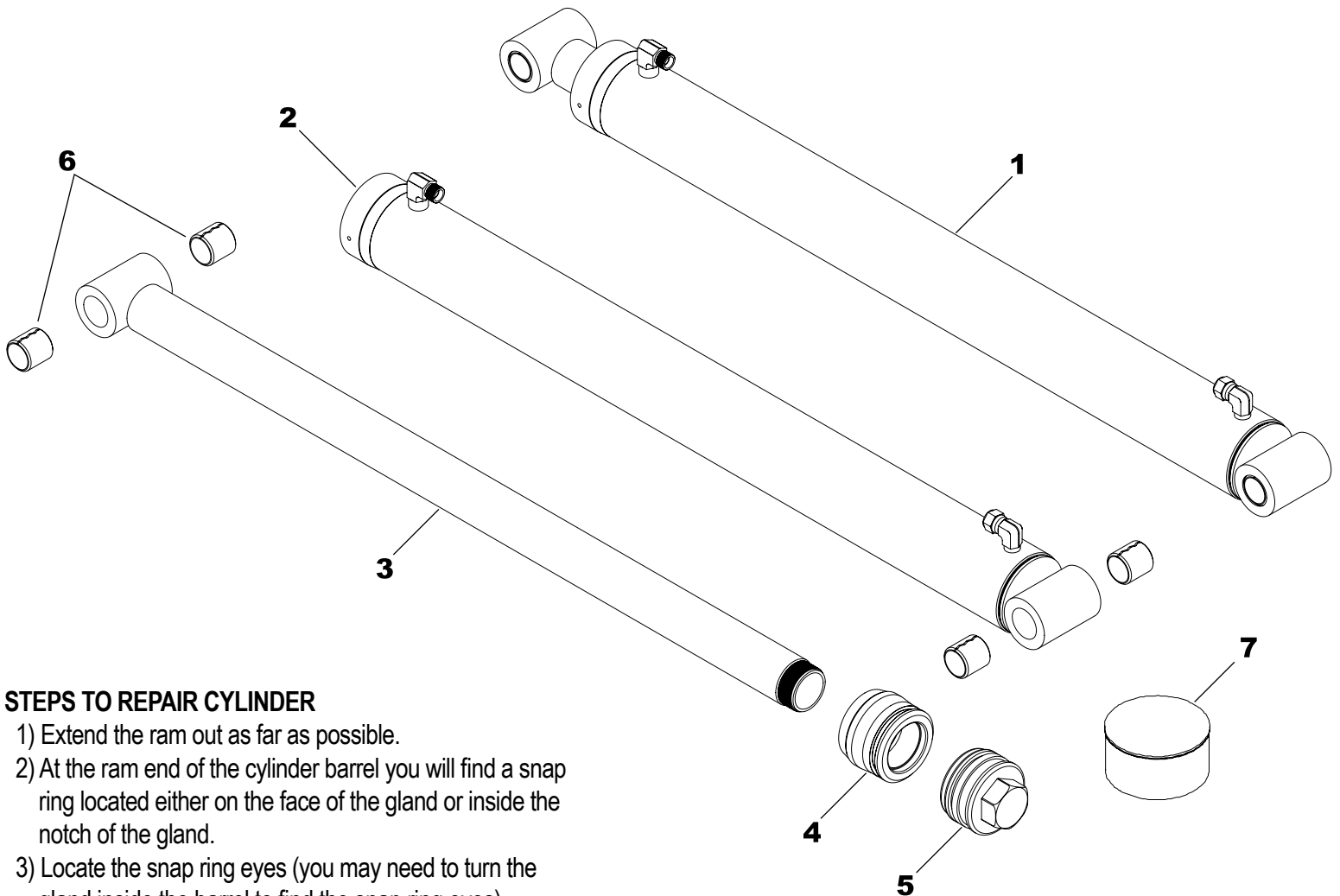

STEPS TO REPAIR CYLINDER

- 1) Extend the ram out as far as possible.
- 2) At the ram end of the cylinder barrel you will find a snap ring located either on the face of the gland or inside the notch of the gland.
- 3) Locate the snap ring eyes (you may need to turn the gland inside the barrel to find the snap ring eyes).
Compress the snap ring with snap ring pliers.
- 4) Remove the ram assembly (ram, gland, & piston) from barrel.
- 5) Notice the direction they are pointing so they can be properly re-assembled.
- 6) Remove the piston and gland from the ram.
- 7) Remove the old seals and rings and replace them with the new seals and rings. (Seal kits are packaged for several different cylinders. You may have extra parts)
- 8) Clean the cylinder with cleaner and a clean lint free cloth.
- 9) Lubricate the seals and rings to aid assembly.
- 10) Assemble the cylinder by reversing the order.

CYLINDER REPAIR TIPS

- When disassembling cylinders, keep the parts in correct orientation. Remove parts in sequence.
- Note the direction of the piston and gland. Lay out old seals and parts as they are removed.
- Assemble cylinder in proper order; lubricate to aid assembly.

LIFT CYLINDER REPLACEMENT PARTS

Ref.	Part No.	Description	Qty.
1	L-64	CYLINDER COMPLETE	1
2	L-6401	CYLINDER BARREL	1
3	L-6410	CYLINDER RAM	1
4	G-U	GLAND	1
5	P-Z	PISTON	1
6	LW-32	INSERT	4
7	#53CK	SEAL KIT*	-

NOTE: *Seal kit contains parts to repair one cylinder.

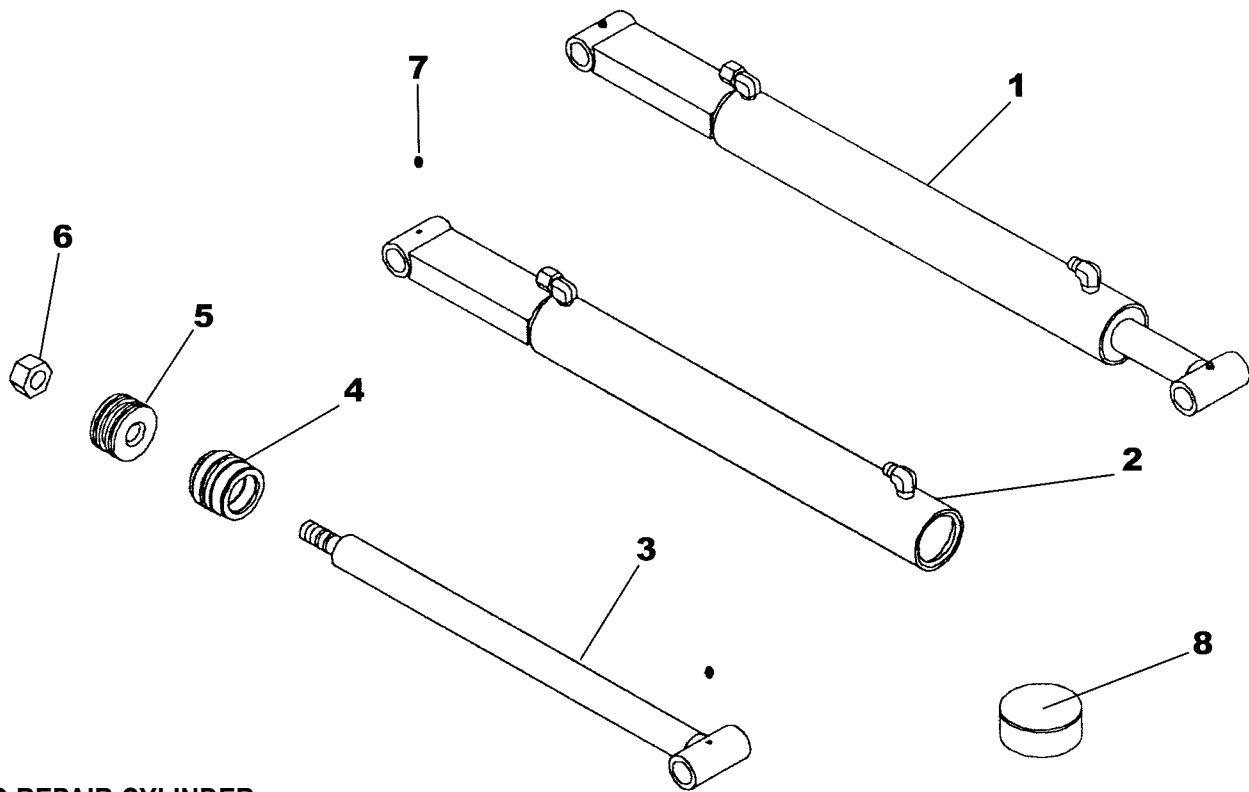

STEPS TO REPAIR CYLINDER

- 1) Remove spiral retaining ring from the top of the gland.
- 2) Gently drive the gland into the barrel using a brass or non-marring punch until the round retaining ring is visible.
- 3) Remove the round retaining ring using a pair of long nose pliers.
- 4) Remove the ram assembly (ram, gland, & piston) from barrel.
- 5) Notice the direction they are pointing so they can be properly re-assembled.
- 6) Remove the jam nut and/or hex nut from the end of the ram.
- 7) Remove the old seals and rings and replace them with the new seals and rings. *(Seal kits are packaged for several different cylinders--you may have extra parts.)*
- 8) Clean the cylinder with cleaner and a clean **lint free** cloth.
- 9) Lubricate the seals and rings to aid assembly.
- 10) Assemble the cylinder by reversing the order.

CYLINDER REPAIR TIPS

- When disassembling cylinders, keep the parts in correct orientation. Remove parts in sequence.
- Note the direction of the piston and gland. Lay out old seals and parts as they are removed.
- Assemble cylinder in the proper order; lubricate to aid assembly.

BUCKET CYLINDER REPLACEMENT PARTS

Ref.	Part No.	Description	Qty.
1	B-24	CYLINDER (COMPLETE)	1
2	B-2401	CYLINDER BARREL	1
3	B-2410	CYLINDER RAM	1
4	G-L	GLAND	1
5	P-B	PISTON	1
6	HFN1614	1" HEX NUT	1
7	ZER1805	GREASE FITTING	2
8	#4CK	SEAL KIT*	-

NOTE: *Seal kit contains parts to repair one cylinder.

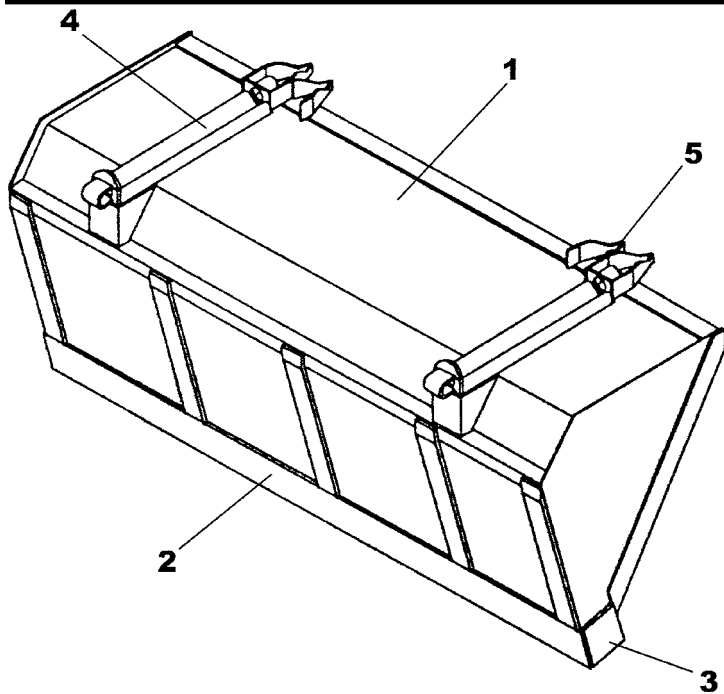

BUCKET

Ref.	Part No.	Description	Qty.
1	96Q729	96" BUCKET COMPLETE	*
	108Q733	108" BUCKET COMPLETE	*
2	CB-14	96" CUTTING EDGE	*
	UB-414	108" CUTTING EDGE	*
3	SB-15	SIDE BLADE	1
4	QC-2AS	RECEIVER ADAPTER	1
5	JB-22	ATTACH GUIDE (OPTION)	1

NOTE: Qty. shows the number of parts you will receive if you place an order using these part numbers.

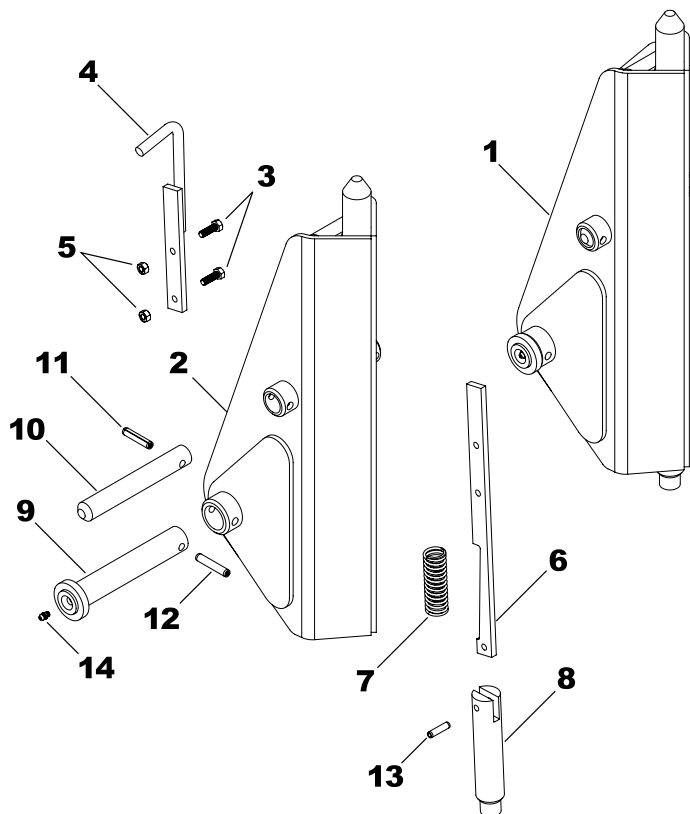

SNAP-ATTACH™ COUPLER (C-4B)

Ref.	Part No.	Description	Qty.
1	QC-1201COM	SNAP-ATTACH™ (COMPLETE)	1
2	QC-1201AS	SNAP-ATTACH™ (SHELL)	1
3	HHS0518016	5/16" x 1" BOLT	2
4	QC-7AS	HANDLE	1
5	HTN0518	5/16" LOCK NUT	2
6	QC-8	LATCH	1
7	QC-12	SPRING	1
8	QC-3	PLUNGER	1
9	XAF-55AS	1-1/4" PIN W/GREASE ZERK	1
10	LF-51A	1" PIN	1
11	DRP0600028	DOUBLE ROLL PIN	1
12	DRP0600032	DOUBLE ROLL PIN	1
13	RLP0500020	5/16" x 1-1/4" ROLL PIN	1
14	ZER1805	GREASE ZERK	1

NOTE: Qty. shows the number of parts you will receive if you place an order using these part numbers. C-4B is two (QC-1201COM).

COSMETICS

Ref.	Part No.	Description	Qty.	Ref.	Part No.	Description	Qty.
1	DEC-700A	DECAL KIT	1	3	V-9524-P	PINT BLACK PAINT	1
2	V-5403-A	RED SPRAY PAINT	1	4	V-9524-Q	QUART BLACK PAINT	1
	V-9524-A	BLACK SPRAY PAINT	1	5	V-9524-G	GALLON BLACK PAINT	1

NOTE: Warning decals are available at no charge. If they become damaged or missing, order Part Numbers DE-CW.