

## TA-52 LOADER REPLACEMENT PARTS

REF #	PART #	DESCRIPTION	QTY
1	MAT-212AS	TOWER	1
2	MAT-204AS	LOADER STAND	1
3	MAF-204AS	FRAME	1
4	MF-49AS	GAUGE ROD	1
5	MF-50AS	GAUGE ROD HOLDER	1
6	MF-69AS	GAUGE ROD TOP BOLT	2
7	MF-230	INSERT BUSHING	6
8	B-1531	INSERT BUSHING	2
9	HHS0616024	3/8" X 1 1/2" BOLT	2
10	CBF1210064	3/4" X 4" CARRIAGE BOLT	5
11	CBF1210072	3/4" X 4 1/2" CARRIAGE BOLT	1
12	HFN0616	3/8" NUT	4

REF #	PART #	DESCRIPTION	QTY
13	HTN1210	3/4" LOCK NUT	8
14	QLP0700024	LYNCH PIN	2
15	SR-C08	SNAP RING	4
16	ZER1805	GREASE FITTING	4
17	CTK0200016	1/8" X 1" COTTER KEY	2
18	48P604	48" BUCKET	*
	54P605	54" BUCKET	*
19	MB-214	48" BLADE	*
	MAB-314	54" BLADE	*
20	MB-115	SIDE BLADE	2
21	DEC-52	DECAL KIT (NOT SHOWN)	1

*NOTE: \*Check width of the bucket and use the part number that matches. If your size is not shown, contact Westendorf Mfg. Co.*

WESTENDORFMFG PWB012021

WESTENDORF MFG CO., INC. • PH: (712) 423-2762 • FAX: (712) 423-1460 • sales@westendorfmfg.com • www.loaders.com

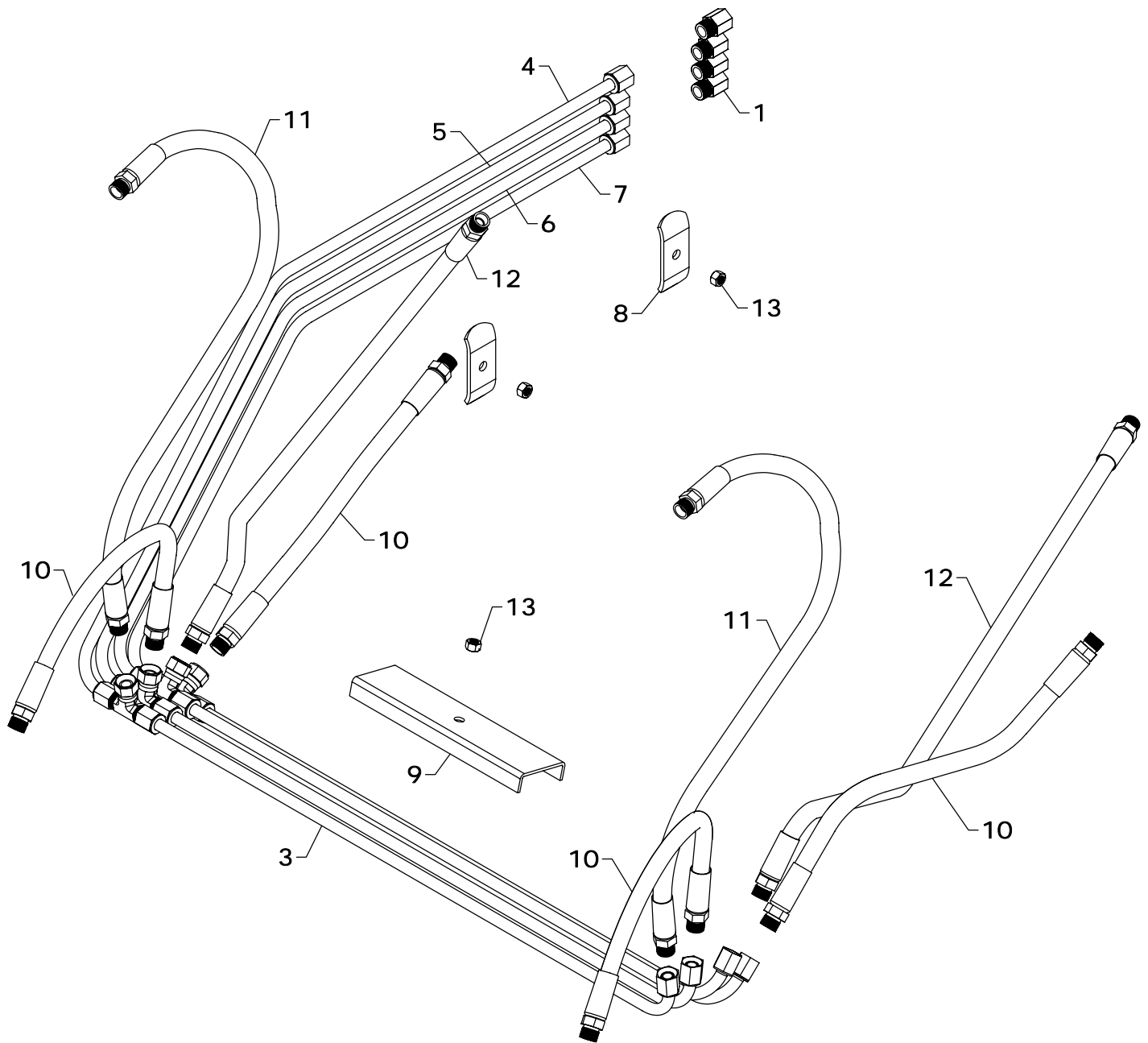

## TA-52 HYDRAULICS

REF #	PART #	DESCRIPTION	QTY.
1	PF-FFC8	FEMALE CONNECTOR	4
2	PF-FSBT8	SWIVEL NUT TEE	4
3	OLT-184	OIL LINE	4
4	OLT-185	OIL LINE	1
5	OLT-186	OIL LINE	1
6	OLT-187	OIL LINE	1
7	OLT-188	OIL LINE	1

REF #	PART #	DESCRIPTION	QTY.
8	OH-3	OIL LINE HOLDER	2
9	OH-11	OIL LINE HOLDER	1
10	H06020-FF	3/8" X 20" HOSE	4
11	H06030-FF	3/8" X 30" HOSE	2
12	H06040-FF	3/8" X 40" HOSE	2
13	HTN0616	3/8" LOCK NUT	3

## TA-52 / TA-54 / TA-55 BUCKET CYLINDER REPLACEMENT PARTS

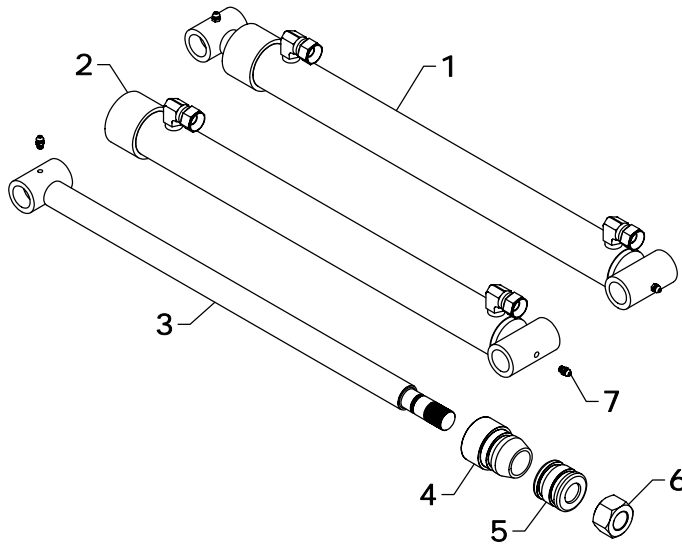

REF #	PART #	DESCRIPTION	QTY.
1	B-25	CYLINDER	1
2	B-2501	BARREL	1
3	L-2510	RAM	1
4	G-N	GLAND	1
5	P-F	PISTON	1
6	HFN1414	7/8" NUT	1
7	ZER1805	GREASE FITTING	2
8	#26CK	SEAL KIT	1

*NOTE: \* Seal kit contains parts to repair one cylinder*

## TA-52 / TA-54 / TA-55 LIFT CYLINDER REPLACEMENT PARTS

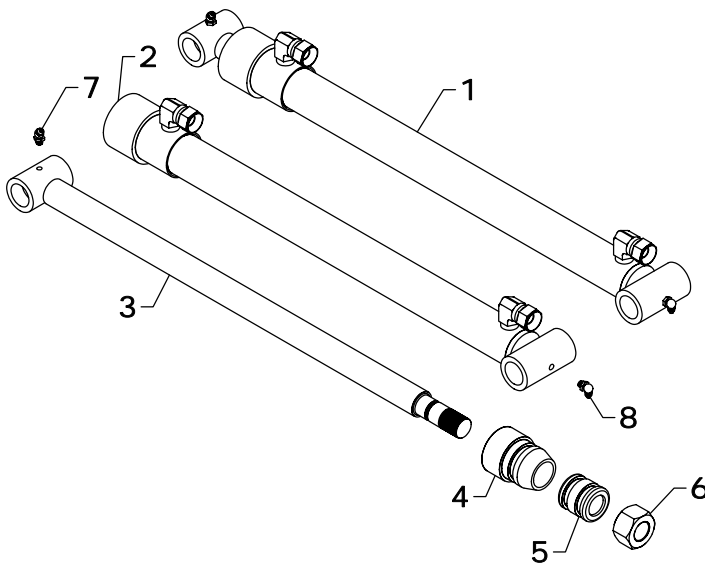

REF #	PART #	DESCRIPTION	QTY.
1	L-25	LIFT CYLINDER	1
2	L-2501	BARREL	1
3	L-2510	RAM	1
4	G-N	GLAND	1
5	P-G	PISTON	1
6	HFN1414	7/8" NUT	1
7	ZER521	45° GREASE FITTING	1
8	ZER523	90° GREASE FITTING	1
9	#25CK	SEAL KIT	1

*NOTE: \* Seal kit contains parts to repair one cylinder*

### STEPS TO REPAIR CYLINDER

- 1) Extend the ram out as far as possible.
- 2) At the ram end of the cylinder barrel you will find a snap ring located either on the face or inside the notch of the gland.
- 3) Locate the snap ring eyes (you may need to turn the gland inside the barrel to find the snap ring eyes). Compress the snap ring with snap ring pliers.
- 4) Remove the ram assembly (ram, gland, & piston) from barrel.
- 5) Notice the direction they're pointing so they can be properly re-assembled.
- 6) Remove the jam nut and/or hex nut from the end of the ram.
- 7) Remove the old seals and rings and replace them with the new seals and rings. (Seal kits are packaged for several different cylinders. You may have extra parts)
- 8) Clean cylinder with cleaner and a clean lint free cloth.
- 9) Lubricate the seals and rings to aid assembly.
- 10) Assemble the cylinder by reversing the order.

### CYLINDER REPAIR TIPS

- When disassembling cylinders, keep the parts in correct orientation. Remove parts in sequence.
- Note the direction of the piston and gland. Lay out old seals and parts as they are removed.
- Assemble cylinder in proper order; lubricate to aid assembly.