

TA-175A TOWER (MET-112AS)

## TA-175 / TA-175A LOADER FRAME AND TOWER REPLACEMENT PARTS

REF #	PART #	DESCRIPTION	QTY.
1	MET-12AS	TOWER (TA-175)	1
	MET-112AS	TOWER (TA-175A)	1
2	MEF-4AS	FRAME	1
3	MDF-10	OUTSIDE PIVOT STRAP	2
4	MDF-11	INSIDE PIVOT STRAP	2
5	MDF-15AS	LINKAGE	2
6	MF-50AS	GAUGE ROD HOLDER	1
7	RF-49	INNER GAUGE ROD	1
8	MT-331	SPACER WASHER	4

REF #	PART #	DESCRIPTION	QTY.
9	MCF-48	SQUARE HEAD WASHER	4
10	B-930	INSERT BUSHING	4
11	B-931	INSERT BUSHING	8
12	MF-69AS	GAUGE ROD TOP BOLT	1
13	CBF1210072	3/4" X 4 1/2" CARRIAGE BOLT	7
14	CBF1210080	3/4" X 5" CARRIAGE BOLT	4
15	HTN1210	3/4" LOCK NUT	12
16	CTK0200016	1/8" X 1" COTTER KEY	2
17	ZER1805	GREASE FITTING	8

WESTENDORFMFG PWB114130

WESTENDORF MFG CO., INC. • PH: (712) 423-2762 • FAX: (712) 423-1460 • sales@westendorfmfg.com • www.loaders.com

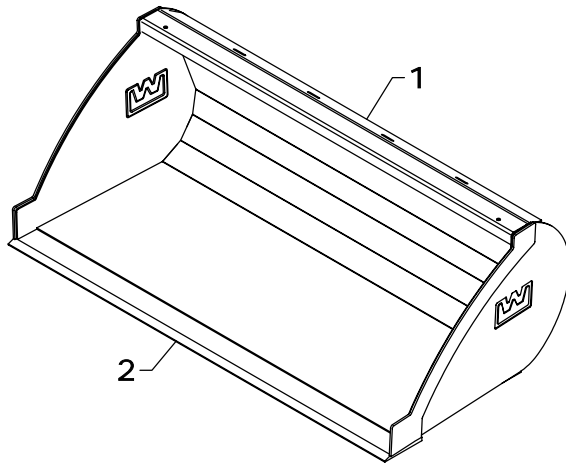

## TA-175 / TA-175A BUCKETS

REF #	PART #	DESCRIPTION	QTY.
1	60QS13	60" SKID STEER BUCKET	1
	66QS14	66" SKID STEER BUCKET	1
	72QS15	72" SKID STEER BUCKET	1
2	AB-14	60" BLADE	1
	IB-14	66" BLADE	1
	JB-14	72" BLADE	1

**NOTE:** \*Check width of the bucket and use the part number that matches. If your size is not shown, contact Westendorf Mfg. Co.

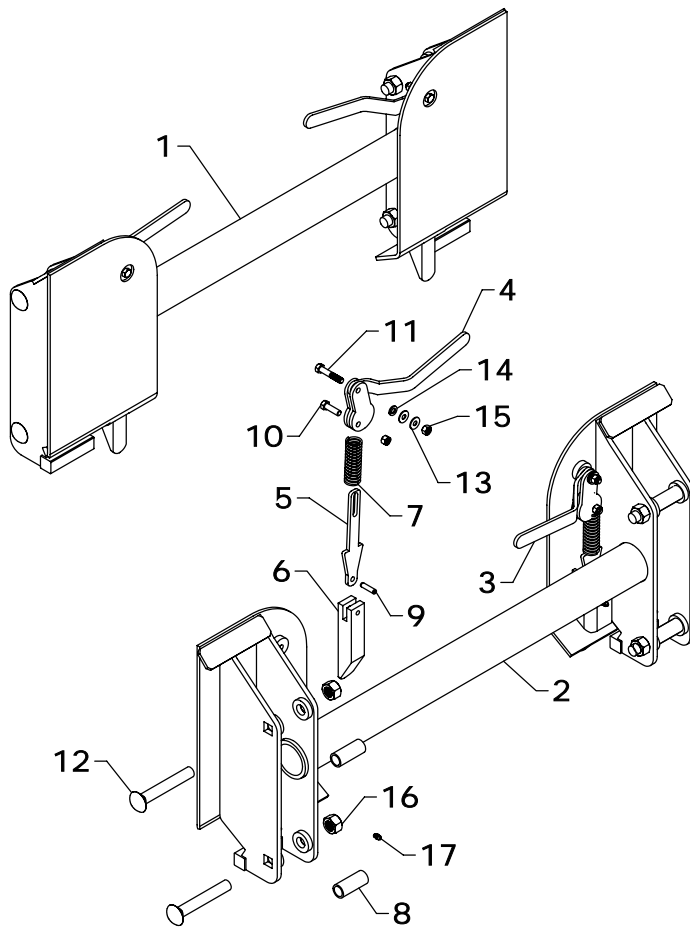

## TA-175 SKID STEER COUPLER (C-22)

REF #	PART #	DESCRIPTION	QTY
1	C-22	SKID STEER COUPLER	1
2	QC-2013AS	COUPLER	1
3	QC-2007AS - R	HANDLE (RIGHT)	1
4	QC-2007AS - L	HANDLE (LEFT)	1
5	QC-2010	LINKAGE	2
6	QC-2011	LATCH	2
7	QC-12	SPRING	2
8	MF-230	INSERT BUSHING	4
9	RLP0500020	5/16" X 1 1/4" ROLL PIN	2
10	HHS0616020	3/8" X 1 1/4" BOLT	2
11	HHS0616032	3/8" X 2" BOLT	2
12	CBF1210080	3/4" X 5" CARRIAGE BOLT	4
13	FWW05	5/16" FLAT WASHER	4
14	LWM06	3/8" LOCK WASHER	2
15	HTN0616	3/8" LOCK NUT	4
16	HTN1210	3/4" LOCK NUT	4
17	ZER1805	GREASE FITTING	2

## TA-175 / TA-175A COSMETICS

REF #	PART #	DESCRIPTION	QTY.
1	DEC-175	DECAL KIT (TA-175)	1
	DEC-185	DECAL KIT (TA-185)	1
2	V-9524-A	BLACK SPRAY PAINT	1

REF #	PART #	DESCRIPTION	QTY
3	V-9524-P	PINT BLACK PAINT	1
4	V-9524-Q	QUART BLACK PAINT	1
5	V-9524-G	GALLON BLACK PAINT	1

**NOTE:** Warning decals are available at no charge. If they become damaged or missing, order part numbers DE-DWWS, DE-WWWS, DE-PP, AND DE-175.

WESTENDORFMFG PWB114130

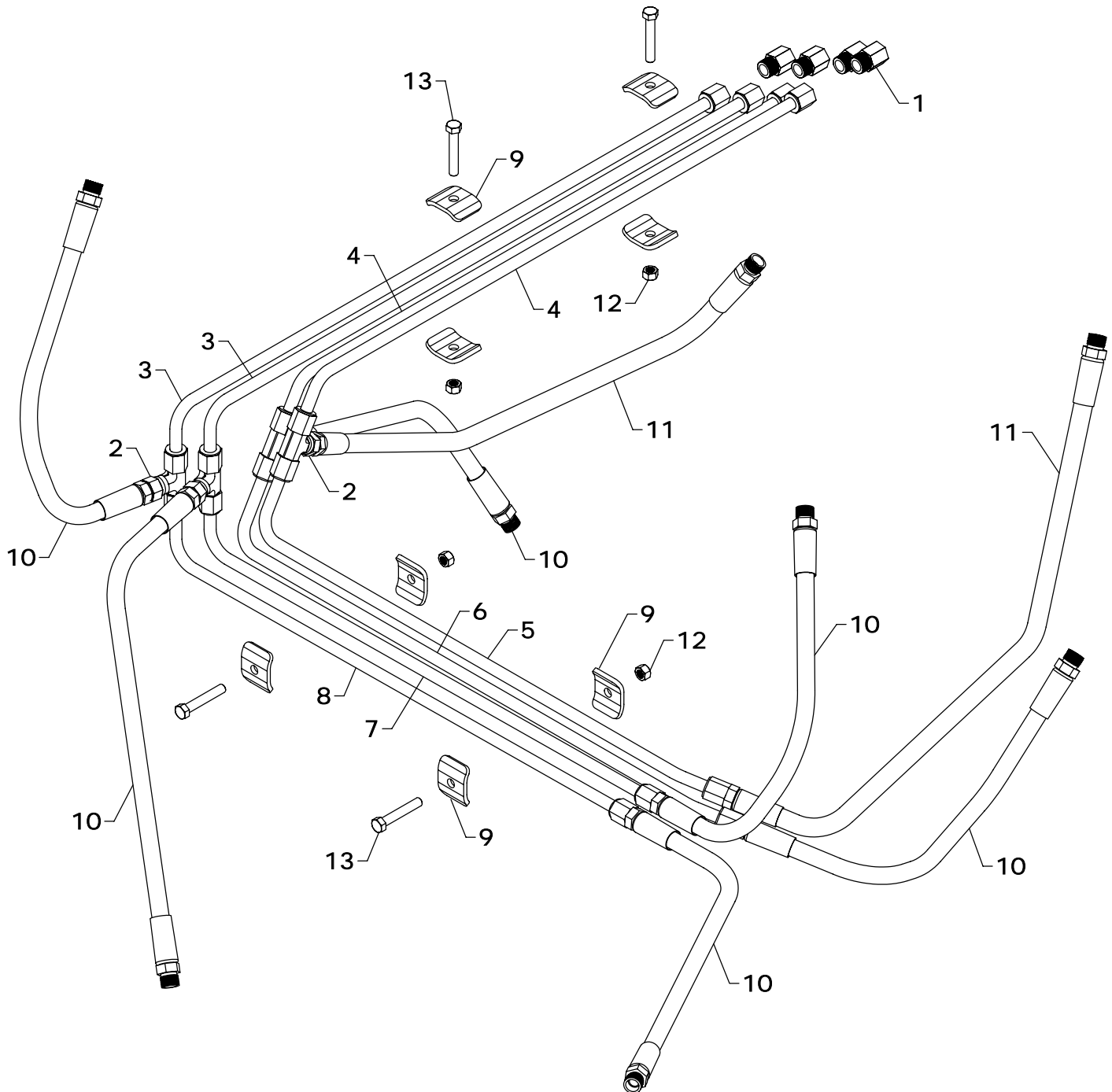

## TA-175 / TA-175A HYDRAULIC LINES

REF #	PART #	DESCRIPTION	QTY.
1	PF-FFC8	FEMALE CONNECTOR	4
2	PF-FSBT8	SWIVEL NUT TEE	4
3	OLT-490	OIL LINE	2
4	OLT-491	OIL LINE	2
5	OLT-492	OIL LINE	1
6	OLT-493	OIL LINE	1
7	OLT-494	OIL LINE	1

REF #	PART #	DESCRIPTION	QTY.
8	OLT-495	OIL LINE	1
9	OH-23	OIL LINE HOLDER	8
10	H06030-FF	3/8" X 30" HOSE	6
11	H06040-FF	3/8" X 40" HOSE	2
12	HTN0616	3/8" LOCK NUT	4
13	HHS0616036	3/8" X 2 1/4" BOLT	4

WESTENDORFMFG PWB114130

WESTENDORF MFG. CO., INC. • PH: (712) 423-2762 • FAX: (712) 423-1460 • sales@westendorfmfg.com • www.loaders.com

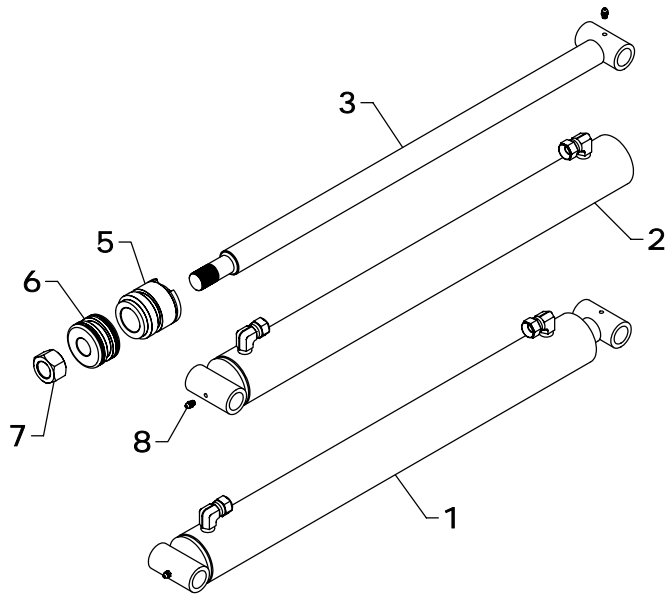

## TA-175 / TA-175A LIFT CYLINDER REPLACEMENT PARTS

REF #	PART #	DESCRIPTION	QTY.
1	L-51	LIFT CYLINDER	1
2	L-5101	BARREL	1
3	L-4010	RAM	1
5	G-A	GLAND	1
6	P-A	PISTON	1
7	HFN1614	1" NUT	1
8	ZER1805	GREASE FITTING	2
9	#1CK	SEAL KIT	*

*NOTE: \* Seal kit contains parts to repair one cylinder*

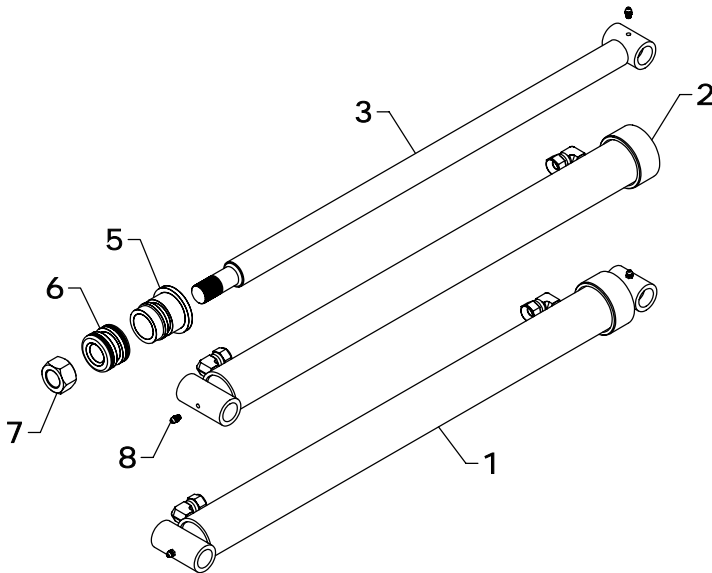

## TA-175 / TA-175A BUCKET CYLINDER REPLACEMENT PARTS

REF #	PART #	DESCRIPTION	QTY.
1	B-41	BUCKET CYLINDER	1
2	B-4101	BARREL	1
3	B-4110	RAM	1
5	G-H	GLAND	1
6	P-C	PISTON	1
7	HFN1614	1" NUT	1
8	ZER1805	GREASE FITTING	2
9	#7CK	SEAL KIT	*

*NOTE: \* Seal kit contains parts to repair one cylinder*

### STEPS TO REPAIR CYLINDER

- 1) Extend the ram out as far as possible.
- 2) At the ram end of the cylinder barrel you will find a snap ring located either on the face or inside the notch of the gland.
- 3) Locate the snap ring eyes (you may need to turn the gland inside the barrel to find the snap ring eyes). Compress the snap ring with snap ring pliers.
- 4) Remove the ram assembly (ram, gland, & piston) from barrel.
- 5) Notice the direction they're pointing so they can be properly re-assembled.
- 6) Remove the jam nut and/or hex nut from the end of the ram.
- 7) Remove the old seals and rings and replace them with the new seals and rings. (Seal kits are packaged for several different cylinders. You may have extra parts)
- 8) Clean cylinder with cleaner and a clean lint free cloth.
- 9) Lubricate the seals and rings to aid assembly.
- 10) Assemble the cylinder by reversing the order.

### CYLINDER REPAIR TIPS

- When disassembling cylinders, keep the parts in correct orientation. Remove parts in sequence.
- Note the direction of the piston and gland. Lay out old seals and parts as they are removed.
- Assemble cylinder in proper order; lubricate to aid assembly.

WESTENDORFMFG PWB114130