

GF-96-3D CAT CLAW GRAB FORK REPLACEMENT PARTS

REF #	PART #	DESCRIPTION	QTY.
1	GF-501AS	GRAB FORK BASE	1
2	GF-537AS	TOOTH FRAME	1
3	GF-414	CYLINDER LOCK WASHER	4
4	OH-24	OIL LINE COVER	1
5	JT-20	PIN	2
6	DRP0600028	DOUBLE ROLL PIN	2
7	CTK0400032	1/4" X 2" COTTER KEY	2
8	HHS0420020	1/4" X 1 1/4" BOLT	12
9	LWM04	1/4" LOCK WASHER	12
10	HFN0420	1/4" NUT	12

REF #	PART #	DESCRIPTION	QTY.
11	HTN0616	3/8" LOCK NUT	3
12	PF-HPFT06	3/8" SWIVEL TEE	2
13	HK-45	3/8" X 48" HOSE (NOT SHOWN)	1
		3/8" X 58" HOSE (NOT SHOWN)	2
		3/8" X 66" HOSE (NOT SHOWN)	1
14	M-10	CYLINDER	2
15	ZER1805	GREASE FITTING	3
16	GF-411	WASHER	2
17	FWW06	3/8" FLAT WASHER	3

NOTE: See page 7.3 for M-10 cylinder breakdown.

WESTENDORFMFG PWB116070

WESTENDORF MFG CO., INC. • PH: (712) 423-2762 • FAX: (712) 423-1460 • sales@westendorfmfg.com • www.loaders.com

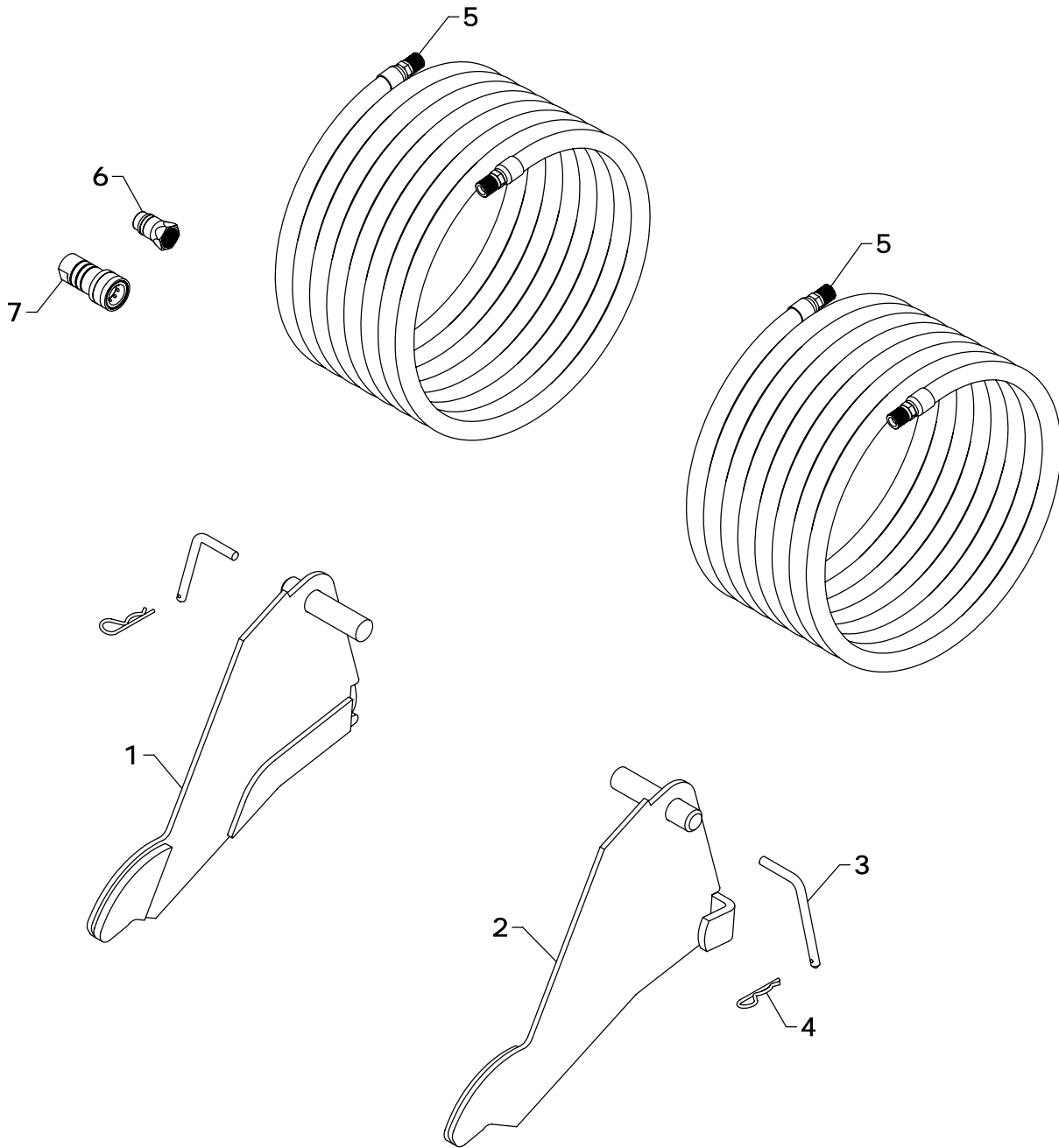

GF-84-3D / GF-96-3D CAT CLAW REPLACEMENT PARTS

REF #	PART #	DESCRIPTION	QTY
1	GF-419AS - R	BUCKET BRACE (RIGHT)	1
2	GF-419AS - L	BUCKET BRACE (LEFT)	1
3	GF-425	3/8 PULL PIN	2
4	HAR-05	HAIR PIN	2

REF #	PART #	DESCRIPTION	QTY
5	HK-21	HOSE KIT (2 - 3/8" X 216" HOSE)	1
	HK-27 *	HOSE KIT (2 - 3/8" X 108" HOSE)	1
6	LM-10	MALE COUPLER	1
7	LM-11	FEMALE COUPLER	1

*NOTE: * For GF-84A-3D and GF-96A-3D (loaders with accessory steel lines)*

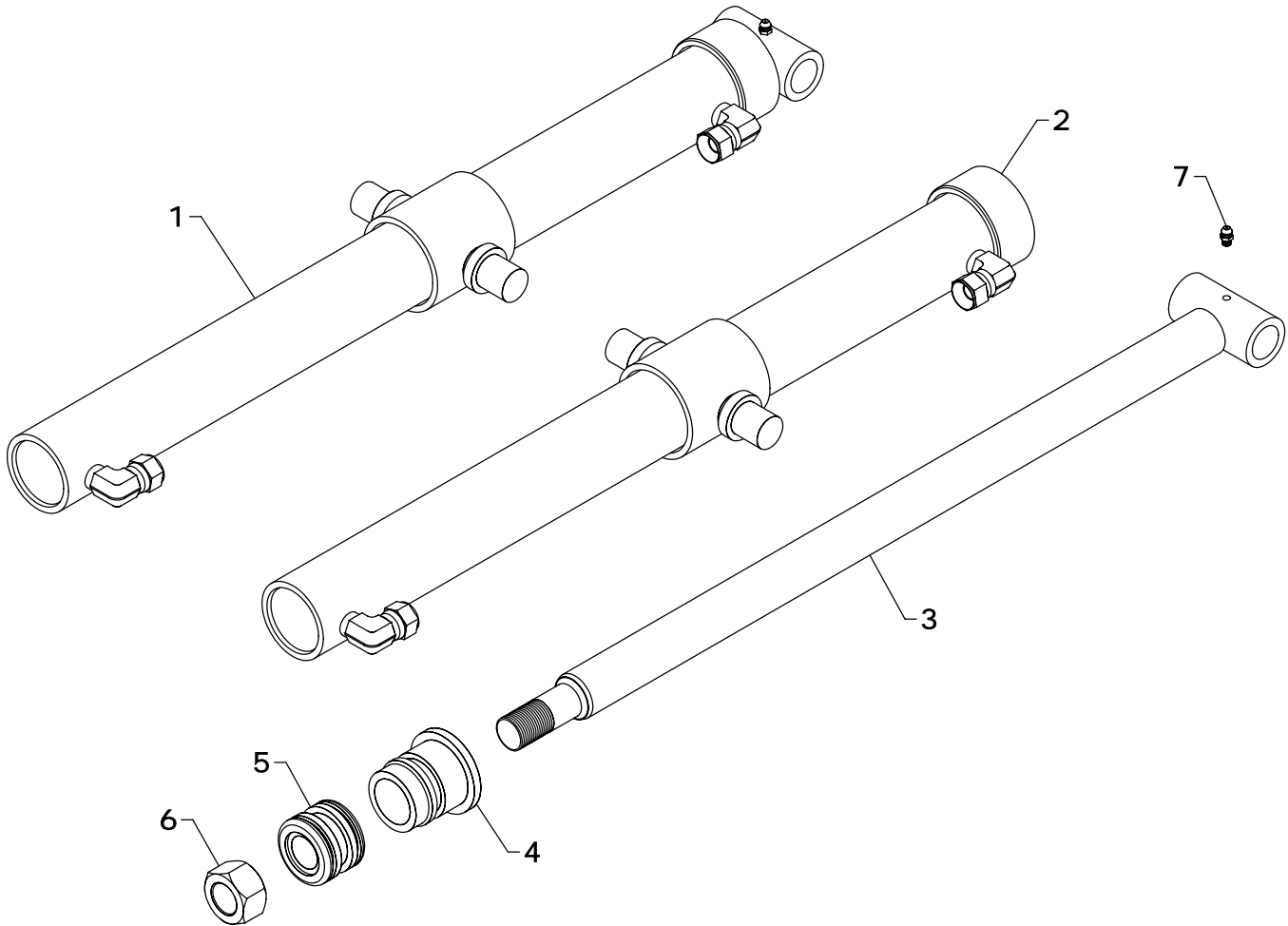

STEPS TO REPAIR CYLINDER

- 1) Extend the ram out as far as possible.
- 2) At the ram end of the cylinder barrel you will find a snap ring located either on the face or inside the notch of the gland.
- 3) Locate the snap ring eyes (you may need to turn the gland inside the barrel to find the snap ring eyes). Compress the snap ring with snap ring pliers.
- 4) Remove the ram assembly (ram, gland, & piston) from barrel.
- 5) Notice the direction they're pointing so they can be properly re-assembled.
- 6) Remove the jam nut and/or hex nut from the end of the ram.
- 7) Remove the old seals and rings and replace them with the new seals and rings. (Seal kits are packaged for several different cylinders. You may have extra parts)
- 8) Clean cylinder with cleaner and a clean lint free cloth.
- 9) Lubricate the seals and rings to aid assembly.
- 10) Assemble the cylinder by reversing the order.

CYLINDER REPAIR TIPS

- When disassembling cylinders, keep the parts in correct orientation. Remove parts in sequence.
- Note the direction of the piston and gland. Lay out old seals and parts as they are removed.
- Assemble cylinder in proper order; lubricate to aid assembly.

GF-84-3D / GF-96-3D CAT CLAW CYLINDER REPLACEMENT PARTS

REF #	PART #	DESCRIPTION	QTY.
1	M-10	CYLINDER	1
2	M-1001	BARREL	1
3	M-1010	RAM	1
4	G-H	GLAND	1
5	P-C	PISTON	1
6	HFN1614	1" NUT	1
7	ZER1805	GREASE FITTING	1
8	#7CK	SEAL KIT	*

*NOTE: * Seal kit contains parts to repair one cylinder*