

## GF-64 GRAB FORK REPLACEMENT PARTS

Ref.	Part No.	Description	Qty.	Ref.	Part No.	Description	Qty.
1	GF-301AS	GRAB FORK FRAME	1	11	GF-315AS	MOUNT BRACKET	4
2	*M-8	HYDRAULIC CYLINDER	1	12	BST-8	HANDLE NUT	4
3	JT-20	LOWER CYLINDER PIN	1	13	GF-316AS	L-BOLT	4
4	LF-51A	UPPER CYLINDER PIN	1	14	FFC-8	FLARELESS TO 1/2" NPT	2
5	RLP0600028	3/8" ROLL PIN	2	15	HK-21	(1) H060196-86 & (1) H060216-86	1
6	RLP0350028	7/32" ROLL PIN	2	15	HK-27	(2) H06108-86 HOSES**	1
7	GF-319AS-L	ALIGNMENT PIN (LEFT)	1	16	LM-10	MALE COUPLER**	1
8	GF-319AS-R	ALIGNMENT PIN (RIGHT)	1	17	LM-11	FEMALE COUPLER**	1
9	HTN0813	1/2" LOCK NUT	4	18	ZER1805	GREASE ZERK	4
10	HHS0813016	1/2" X 1 BOLT	4				

NOTE: \*See page 7.4 for M-8 individual parts breakdown. \*\*For GF-64A grab fork.

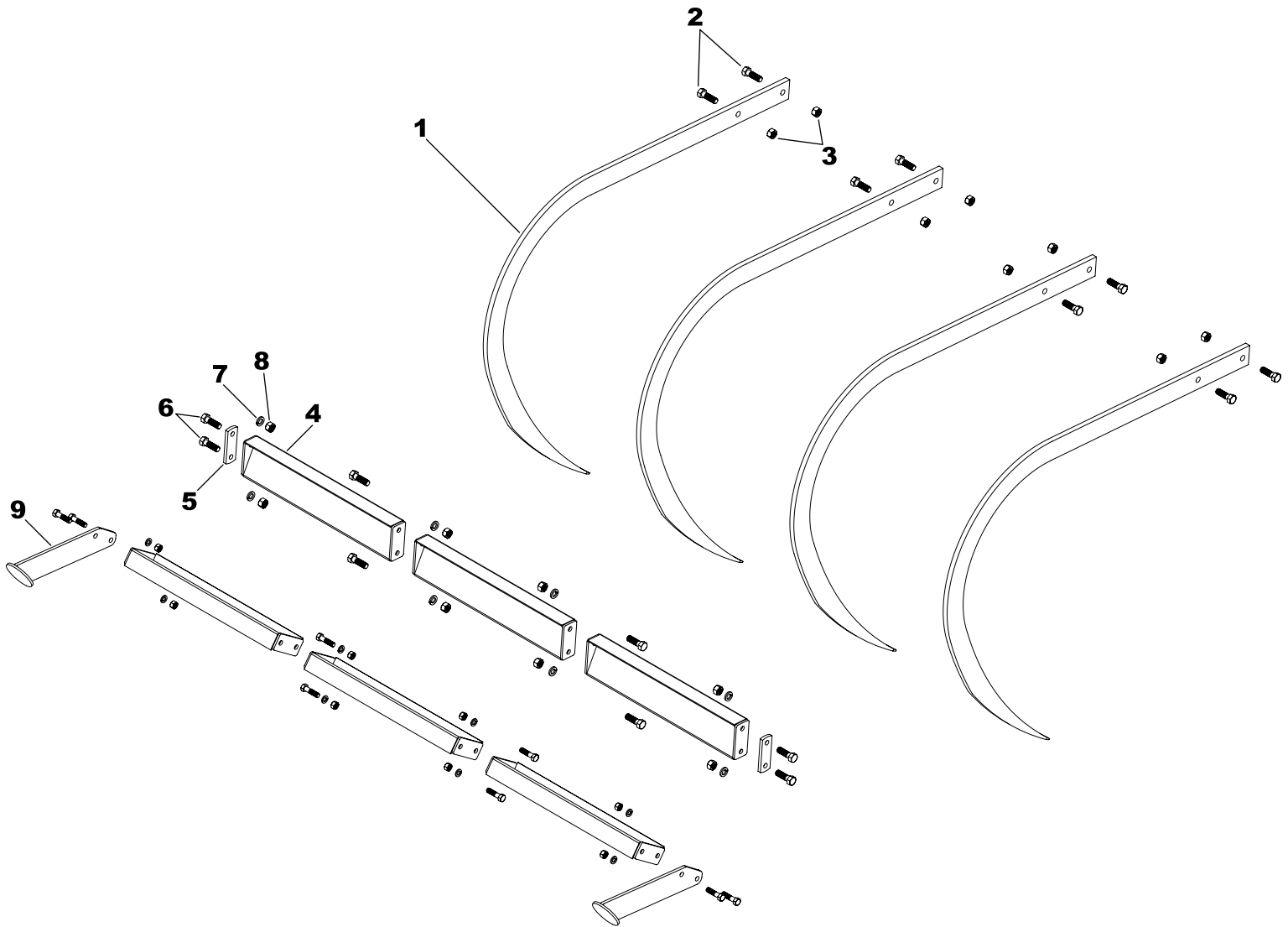

## GF-64 TOOTH ASSEMBLY REPLACEMENT PARTS

Ref.	Part No.	Description	Qty.
1	GF-337	TOOTH	4
2	HHS1011032	5/8" X 2" BOLT	8
3	HTN1011	5/8" LOCK NUT	8
4	GF-327AAS	Z-BRACE	6
5	GF-328	CLAMP PLATE	2
6	HHS0813032	1/2" X 2" BOLT	16
7	LWM08	1/2" LOCK WASHER	16
8	HFN0813	1/2" NUT	16
9	GF-325AAS	STAND	2

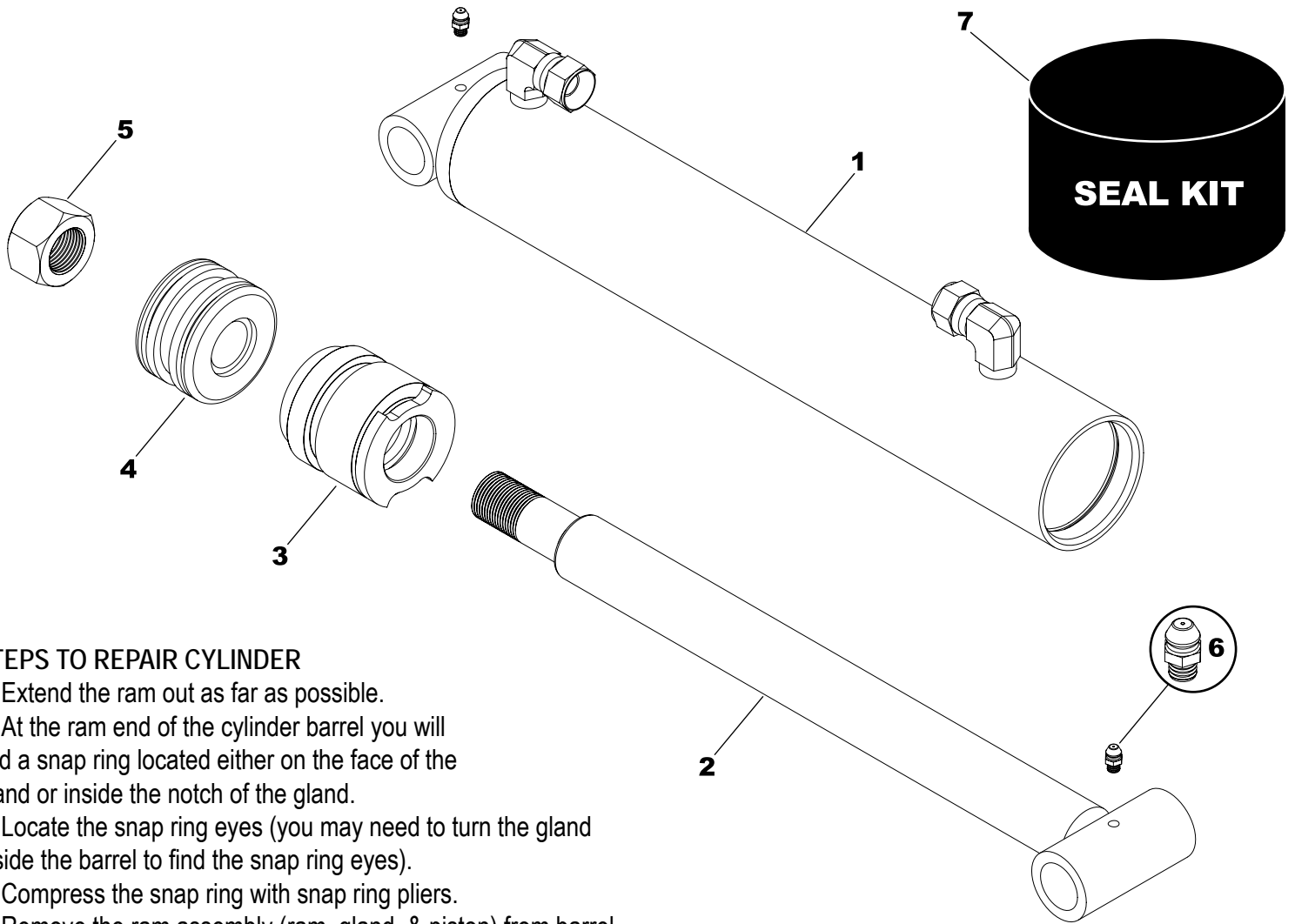

## STEPS TO REPAIR CYLINDER

- 1) Extend the ram out as far as possible.
- 2) At the ram end of the cylinder barrel you will find a snap ring located either on the face of the gland or inside the notch of the gland.
- 3) Locate the snap ring eyes (you may need to turn the gland inside the barrel to find the snap ring eyes).
- 4) Compress the snap ring with snap ring pliers.
- 5) Remove the ram assembly (ram, gland, & piston) from barrel.
- 6) Notice the direction they are pointing so they can be properly re-assembled.
- 7) Remove the jam nut and/or hex nut from the end of the ram.
- 8) Remove the old seals and rings and replace them with the new seals and rings. (*Seal kits are packaged for several different cylinders - you may have extra parts.*)
- 9) Clean the cylinder with cleaner and a clean *lint free* cloth.
- 10) Lubricate the seals and rings to aid assembly.
- 11) Assemble the cylinder by reversing the order.

## CYLINDER REPAIR TIPS

- When disassembling cylinders, keep the parts in correct orientation. Remove parts in sequence.
- Note the direction of the piston and gland. Lay out old seals and parts as they are removed.
- Assemble cylinder in the proper order; lubricate to aid assembly.

## GF-64 GRAB FORK CYLINDER REPLACEMENT PARTS

Ref.	Part No.	Description	Qty.
1	M-801A	CYLINDER BARREL	1
2	M-810	CYLINDER RAM	1
3	G-A	CYLINDER GLAND	1
4	P-A	PISTON	1
5	HFN1614	1" HEX NUT	1
6	ZER1805	GREASE ZERK	1
7	#1CK	SEAL REPAIR KIT*	-

**NOTE:** \*Seal kit contains parts to repair one cylinder.